



Filters . Accumulators

Duplex Inline Filters Type-10/25/100-D



Filters for continuous operation

Wide application

Optimised flow characteristics

Low pressure drop

*Special high efficient
Filter media*

*Operating pressure: 10/25/100 bar
Connection up to DN 100*



Application

Filtering hydraulic fluids, lubricating oils and liquids. Suitable for assembly into pipelines. Used where continuous operation is required and where interrupting operation for the purpose of filter maintenance must be avoided.

Design

These filters consist of two welded steel construction filter housings connected by stub pipes via a control housing with segment changeover. The inlet and outlet connections are on the same side with the inlet on the top. The changeover mechanism makes changeover of the fluid flow possible from the contaminated to the clean filter housing without cross-section reduction.

The filter top covers are provided with vent arrangements while the housings are provided with drain arrangements. The filters are mounted either with two angle plates or on legs.

Filter Element

Pleated design with optimal pleat density and in various filter materials. Further detailed information can be found in our "Filter Elements" filter brochure.

Optional Accessories

Maintenance Indicator.

For monitoring the degree of clogging of the filter elements. Available in Optical / Optical-Electrical / DP Gauge / DP Switch options.

Permanent Ring Magnet.

For removal of ferrous contaminants from the fluid.

Bypass Valve.

To protect the filter element during start-up and over pressurisation due to clogging.

Air release / vent valve.

For removing the air from the filter during start-up and for safe depressurisation.

Drain valve.

For easy removal of the contaminated fluid from the filter housing.

Performance characteristic curves

ΔP -Q-characteristic curves for complete filter

Oil viscosity : 30 mm²/s [30 cSt]

Specific weight : ≤ 0.9 kg/dm³

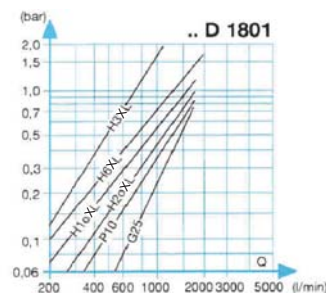
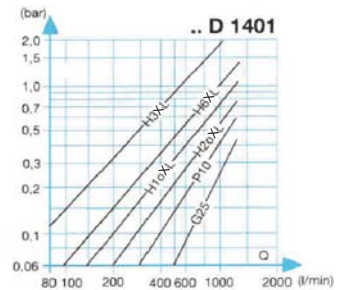
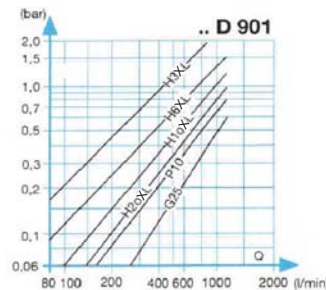
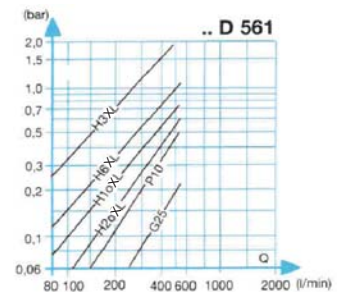
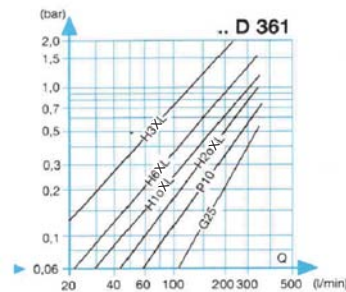

Ordering Information

Special design available on request.

Filter Type D Duplex Inline	Magnet 0 without 2 fitted	Maintenance Indicator Design O without A..Visual B..Visual-Electrical C..Visual-Electrical with lamp G..DP Gauge S.. DP switch X.. DP Gauge+Switch Switch Pressure ..1.5 1.5 bar ..2.0 2.0 bar ..2.5 2.5 bar ..5.0 5.0 bar	Connection Port Connections F..Sq Flange D..DIN Flange S..SAE Flange Port positions O. Inline-inlet & outlet in same line Changeover Design ..0 Single piece segment valve ..1 Two piece segment valve ..2 Two piece Ball Valve	Material O Standard
---------------------------------------	--	--	--	-------------------------------

Filter Assembly → 25 D 361 H10XL - A 00 - 2 8 A5.0 - F00 P 0 A
 Seal Kit → D 25 D 361 - A - F00 P 0

Pressure	Nominal Size	Filter Media & Filtration Grade	Diff. Pressure	Element Model	Bypass Valve	Seal	Addl. Info
10 10 bar 25 25 bar 100 100 bar	361 451 561	Nominal filtration grade in µm G= stainless steel wire mesh, cleanable G10 G25 G40 G60 G80 G100 VS=bonded fabric, not cleanable VS 25 VS 40 VS 60 P=paper, not cleanable P5 P10 P25	A 30 bar o 15 bar	O...Standard adhesive T=100°C	O without 4 2 bar 8 5 bar	P Nitrile V Viton	O Without E Air Vent Valve D Drain Valve A Pr.Eq. Valve
Filter Element 1. Both sides open O-ring sealing	1401 1801 1801/0270	Absolute filtration grade (ISO16889) in µm H..XL=micro glass, not cleanable H1XL H3XL H6XL H10XL H20XL AS= micro glass-fibre, water absorbing, not cleanable AS1 AS3 AS6 AS10 AS20		O...Standard material	For filter element always '0'		

Filter Element → 1 361 H10XL - A 00 - 0 P -

Maintenance Indicator

The maintenance indicator monitors the degree of clogging of the filter elements. They are available as visual/electrical displays. See "Maintenance Indicator" catalogue for technical data.

Filter Switching Symbol

A...Optical	B... Optical/electrical	D...Visual/electrical With two signal lights and two switching points
Ordering information A2,5 = F2,5 A0 00 00P* A5,0 = F5, 0 A0 00 00P*	Ordering information B2,5 = F2,5 GW 02 00P* B5,0 = F5,0 GW 02 00P*	Ordering information D2,5 = F2,5-GW-26-00-P* D5,0 = F5,0-GW-26-00-P*
	Switch Symbol 	Switch Symbol

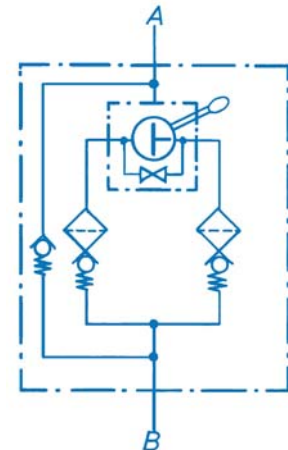

* Buna N / Nitrile, V = Viton, E = Ethylene propylene; N = Neoprene possible

Figure 1
10/25 D 361-451 100 D 361-451

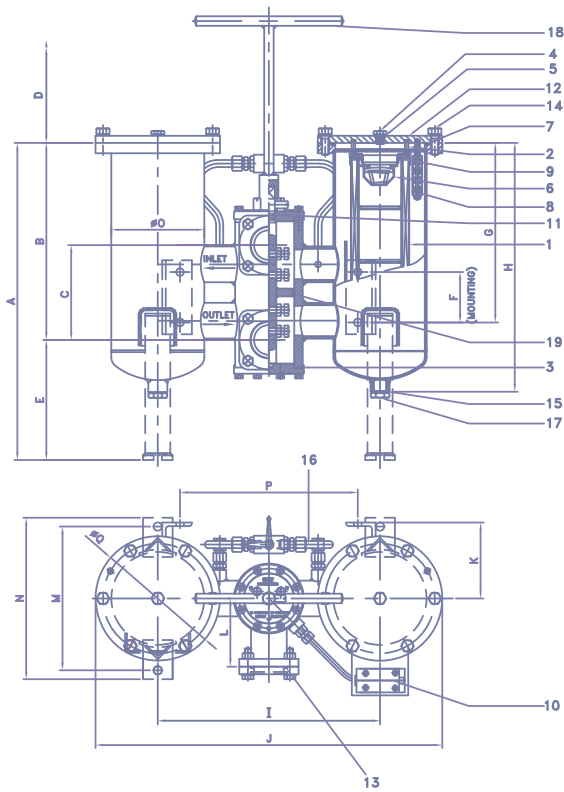
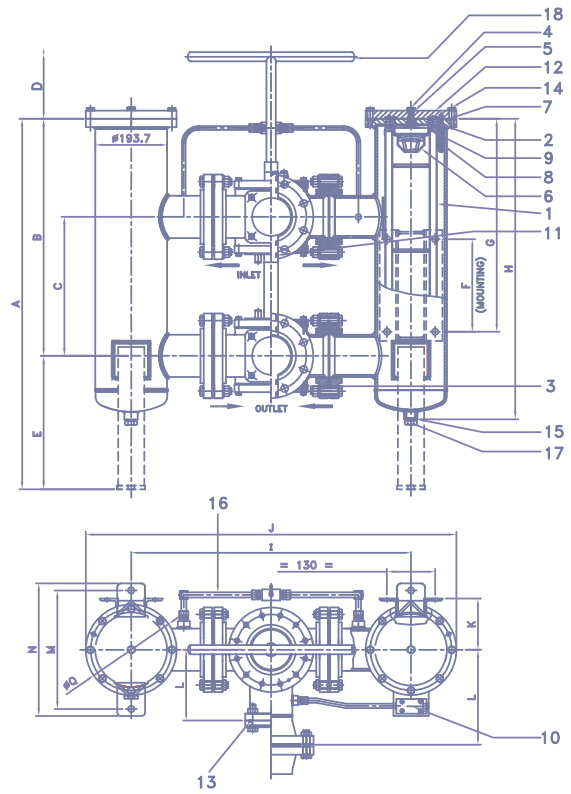

Figure 2
10/25 D 561-1801/0270 100 D 561-1801/0270



Equipment dimensions

Fig	Type		Connections	V in m/s	Weight (kgs)	A	B	C	D	E	F	G	H	I	J	K	L	M	N	O	P	Q
	PN	L/min																				
1	10/25	D 361	Sq.Fl.DN50	3	38	539	334	160	230	205	85	303	428	376	586	128	115	245	275	159	300	210
	100		DIN Fl.DN50		90	571	334	160	230	205	85	303	460	376	616	128	115	245	275	159	300	225
	10/25	D 451	Sq.Fl.DN50	3	44	600	395	160	285	205	85	365	489	376	586	128	115	245	275	159	300	210
	100		DIN Fl.DN50		100	632	395	160	285	205	85	365	521	376	616	128	115	245	275	159	300	225
2	10/25	D 561	Sq.Fl.DN80	1.8	63	637	355	150	260	282	110	350	518	460	705	146	176	286	316	193.7	420	245
	100		DIN Fl.DN80		131	658	355	150	260	282	110	350	539	460	735	146	176	286	316	194	420	260
	10/25	D 901	Sq.Fl.DN80	3	78	761	470	300	380	291	110	400	641	730	975	140	150	286	316	193.7	420	245
	100		DIN Fl.DN80		145	782	470	300	380	291	110	400	662	730	1005	140	150	286	316	194	420	260
	10/25	D 1401	Sq.Fl.DN100	3	105	1005	645	375	510	360	250	580	811	780	1025	140	191	320	358	193.7	420	245
	100		DIN Fl.DN100		197	1005	645	375	510	360	250	580	811	780	1055	140	191	320	358	194	420	260
	10/25	D 1801	Sq.Fl.DN100	3.8	110	1210	850	375	750	360	250	785	1021	780	1025	140	191	320	358	193.7	420	245
	100		DIN Fl.DN100		205	1210	850	375	750	360	250	785	1021	780	1055	140	191	320	358	194	420	260
	10/25	D 1801/0270	Sq.Fl.DN100	3.8	130	1465	1105	375	980	360	250	1041	1277	780	1025	140	191	320	358	193.7	420	245
	100		DIN Fl.DN100		245	1465	1105	375	980	360	250	1041	1277	780	1055	140	191	320	358	194	420	260

All dimensions are in mm.

Note : Technical specifications are subject to change.

Spare part list

Item #	Type/Size	25 D	100 D	25 D	100 D	25 D	100 D	25 D	100 D	25 D	100 D	25 D	100 D	25 D	100 D		
	Designation	361		451		561		901		1401		1801		1801/0270			
1	Filter element	2/1.361		2/1.451		2/1.561		2/1.901		2/1.1401		2/1.1801		2/1.0270			
2	Pressure spring or plate	2				8											
3	O-ring/ flat gasket	2 114x86x2	2 90x3	2 114x86x2	2 90x3	2 159x130x1	2 140x4	2 159x130x1	2 140x4	2 193x161x2	2 108x3.5	2 193x161x2	2 108x3.5	2 193x161x2	2 108x3.5		
4	Locking screw DIN 910-ER Air release/Vent valve	2/ G ¼															
5	Scaling ring DIN 7603	2/A 14x18															
6	Bypass valve	2 or blanking plate															
7	O-ring	2/ 156x4				2/ 192x4											
8	Permanent magnet	6/ PM1				6/ PM2				6/ PM3							
9	O-ring	4/ 60x3.5				4/ 94x5											
10	Maintenance indicator or locking screw	1/ F... 2/ M12x1.5															
11	O-ring	2/ 15x3				2/ 16x3				2/ 29x3							
12	Filter Top Cover	2	2	2	2	2	2	2	2	2	2	2	2	2	2		
13	O-ring	2/55x3.5	-	2/55x3.5	-	2/ 90x3	-	2/ 90x3	-	2/ 108x3	-	2/ 108x3	-	2/ 108x3	-		
14	Hexagonal head screw	12 M12x30	16 M16x65	12 M12x30	16 M16x65	16 M12x35	24 M16x70	16 M12x35	24 M16x70	16 M12x35	24 M16x70	16 M12x35	24 M16x70	16 M12x35	24 M16x70		
15	Sealing ring	2/ A 22x27				2/ A 27x32											
16	Pressure equalisation assy	1				1				1							
17	Locking screw DIN 910	2/ G½				2/ G¾											
18	Change Over handle	1/size 5	1/size 1	1/size 5	1/size 1	1/size 6	1/size 7	1/size 6	1/size 7	1/size 8	1/size10	1/size 8	1/size10	1/size 8	1/size10		
19	O-ring gasket	1/ 72x4				1/ 108x3				1/ 140x4							

Note : Technical specifications are subject to change.



Filters . Accumulators

Filter Assembly and Initial Operation

Check the system maximum pressure against the pressure on the name plate.

Screw the filter to the mounting support at the fixing angles and flanges, depending on the type. Make sure the flow direction lines up with the arrows and take into account the removal space of the element both towards the top and the bottom.

When the blanking plugs have been removed, install filter into the pipeline stress-free.

Initial operation

Bring changeover lever to the middle position, to fill both filter housings.

Open air vent valve. Close again when the fluid escapes.

Put filter in operating position making sure that the changeover lever or pin is at the stop.

The changeover lever or stop pin always shows the operating position.

The filter is now ready for operation.

Filter Element change

If the red pin comes out of the maintenance indicator at normal operating temperature, or if a switch procedure is tripped in the electrical indicator, the filter housing in operation is contaminated and the filter element must be changed.

Open the pressure equalisation valve, switch changeover lever or stopcock key in opposite direction to the stop on the clean filter housing. Close pressure equalisation valve again.

Open the air-vent valve and release the pressure.

If required, drain the housing through the drain valve / plug.

Unscrew and remove the filter top cover.

Pull the filter element from the housing with slight forward and backward movements.

Clean reusable elements as per the specified procedure (refer "Filter Elements" datasheet).

Clean the magnets.

Place new or cleaned elements on the shaft / spigot in the filter housing and assemble.

Ensure that the valves, pressure springs and gaskets are correctly positioned. Replace faulty gaskets.

Start as per section "Initial Operation".

Then change over so that the cleaned filter side is not in operation. This ensures even wear of both the filter sides.

EPE PROCESS FILTERS & ACCUMULATORS PVT LTD

Techni Towers

C-54/A, A.P.I.E., Balanagar

Hyderabad -500 037, A.P., India.

Tel. Nos. : 23778803/23778804/23871445

Fax Nos. : 040-23871447.

Internet : www.epe-india.com

E-mail : business@epe-india.com

Technical specifications are subject to change!