



Filters . Accumulators
an ISO 9001 Company

General

The accumulators should be properly fitted / clamped on the system.

Clamping should not cause the shell or the accumulator connection to be stressed due to over tightening. It is necessary, especially with larger capacities / lengths, horizontal mounting or with heavy units, to use fasteners (clamps, brackets etc) that support the accumulator and prevent dangerous vibrations.

To achieve a high degree of efficiency, the accumulator should be fitted as close as possible to the installation it serves. The space necessary for charging & gauging kit is atleast 150mm above the gas fill valve.

Position

It is suggested that the accumulators are installed vertically with gas side on top. The manufacturers name plate stating the initial pressure must be visible. Moreover access to the vent screw must be kept unobstructed.

The mounting must be such that, should a rupture occur on the pipe system at the liquid connection, or should the gas fill valve break, the accumulator cannot be pulled from its mounting by the forces involved.

No welding or other mechanical process must be carried out on the accumulator shell for the purpose of attaching fasteners.

Mounting Accessories (Brackets/Clamps)

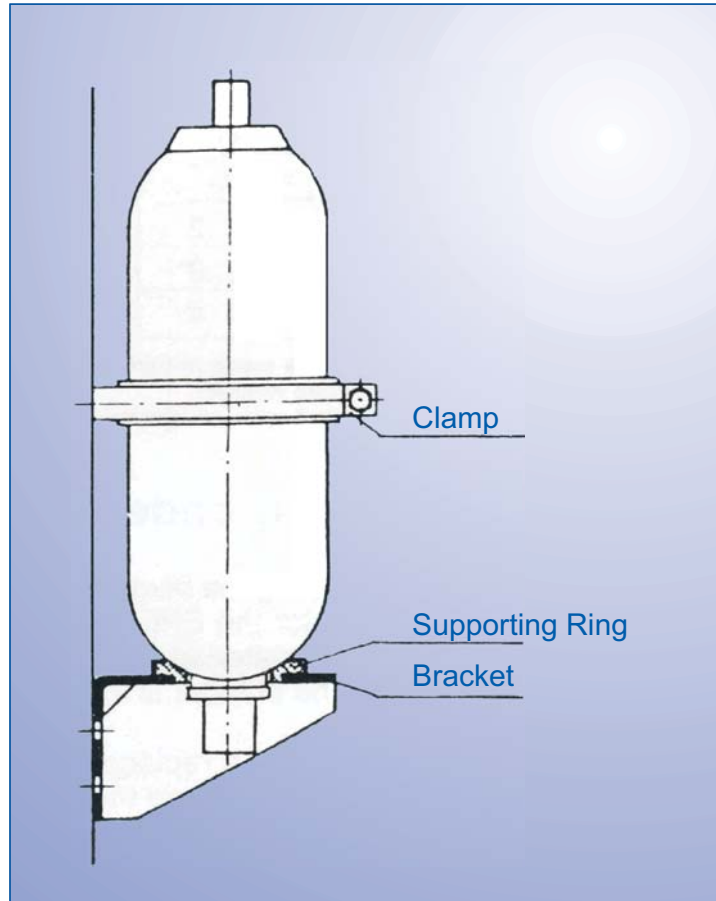

Construction

Clamps / Brackets : Galvanised carbon steel.
SS (on request)

Rubber support ring : Nitrile / Buna N



Techni Towers
C-54/A, A.P.I.E., Balanagar
Hyderabad -500 037. A.P., India.
Tel. Nos. : 23778803/23778804/23871445
Fax Nos. : 040-23871447.
Internet : www.epe-india.com
E-mail : business@epe-india.com.



Note : Technical specifications are subject to change.

Catalogue Ref. : EPE/NP/001

Clamps

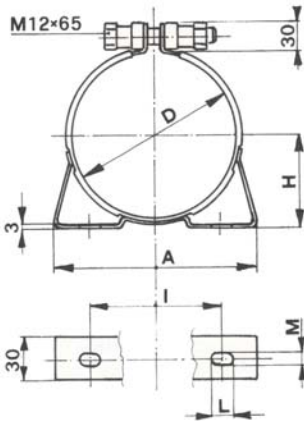

fig. I

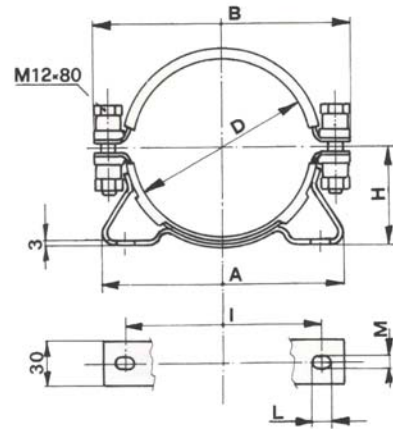
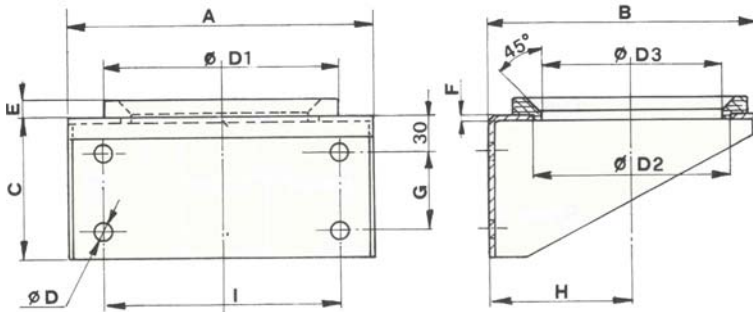

fig. II

Dimensions & Order codes

Accumulator Type	Max. Press. (bar)	Part No.	Fig.	Weight (kg)	A	B	D	H	I	L	M
AS 0.7	330 - 550	10155	I	0.65	125	-	89 - 93	53 - 55	90	13	9
AS-1,1.5,3	70-330	10156	I	0.75	138	-	114 - 118	66 - 68	100	13	9
AS-1,1.5,3	70-330	10157	II	0.85	135	180	114 - 122	66 - 70	100	13	9
AS-1.5,3	550										
AS-5	50-330	10264	I	0.95	185	-	166 - 170	92 - 94	148	13	9
		10250	II	1.1	185	235	167 - 176	95 - 100	146	13	9
AS-10-55	30-330	10410	II	1.35	250	285	215 - 227	120 - 126	216	17	11

Brackets with ring



Support ring

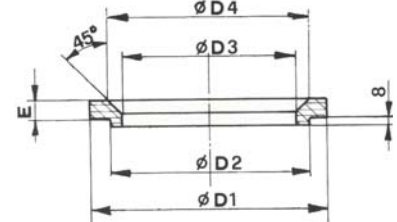

Dimensions & Order codes

Accumulator Type	Part No.		Weight (kg)	A	B	C	φ D	φ D1	φ D2	φ D3	φ D4	E	F	G	H	I
	Bracket with ring	Support ring														
AS 5	10263		1.5	200	175	90	11	140	120	90		10	3	40	96	140
AS-10-55	10363		3.6	260	232	120	17	200	170	150		15	4	70	125	200
AS-1-5		10266	0.13					140	120	90	112	10				
AS-10-55		10345	0.22					200	170	150	175	15				